

电动汽车直流快速熔断器 North American Power fuses

Kaiert Electric Cars High Speed fuses



Kaiert is a company which designs, manufactures, sells and markets electric materials and has a wide range of product available to cover all your installation. A wide spread sales organization offers our customers a rapid service. At Kaiert we are always looking for young dynamic persons interested in joining a multinational company; in order to improve professional development, we offer possibility of developing a solid working career.

Product safety is our most important assets, and for this reason at Kaiert, we have a whole set of advanced equipments to ensure the product quality. Our company firmly carries out the 3C、ISO 90001-2008 standard.

Kaiert fuses protect power semiconductors from the effects of shortcircuits because the super quick disconnect characteristic is far quicker than that of conventional LV HRC fuses. They protect expensive devices and system components such as converters with fuses in the input and in the DC link, UPS systems and soft starters for motors. The fuses for thyristor sets, railway rectifiers or electrolysis systems were developed specially for these applications.

Specifications

Description: North American style stud-mount fuses.

Features and Benefits

- Excellent dc performance
- Low arc voltage and low energy let-through (I^2t)
- Low watts loss
- Superior cycling capability

Typical Applications

- DC common bus
 - DC drives
 - Power converters/rectifiers
- Reduced voltage starters

www.Kaiertfuses.com

Xi'an kaiert power electronic manufacturing CO.,LTD

电动汽车直流快速熔断器 Protection Electric Cars fuses

North American Power fuses

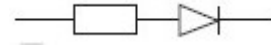

Class:aR

I_e (A)	U_e (V) AC/VDC	KAIERT number	Pre- I^2t -value (A^2S)	Total I^2t -value (A^2S)	Power Loss(W)
70	150/150	KRA-70B	467	4000	6.7
80		KRA-80B	670	6000	7.7
100		KRA-100B	1200	12000	9.0
125		KRA-125B	1870	18000	11.2
150		KRA-150B	2700	26000	13.5
200		KRA-200B	4780	45000	17.6
250		KRA-250B	7470	70000	22.5
300		KRA-300B	10760	100000	27
350		KRA-350B	15700	140000	30.6
400		KRA-400B	20340	180000	35.2
500		KRA-500B	39000	190000	35
600		KRA-600B	46000	200000	47
700		KRA-700B	75000	220000	49
800		KRA-800B	92000	280000	58
1000		KRA-1000B	170000	510000	60

Dimensions (mm)

Fig. 1: 70-400A

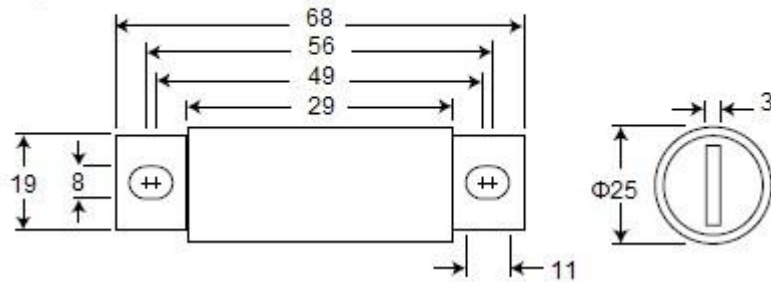
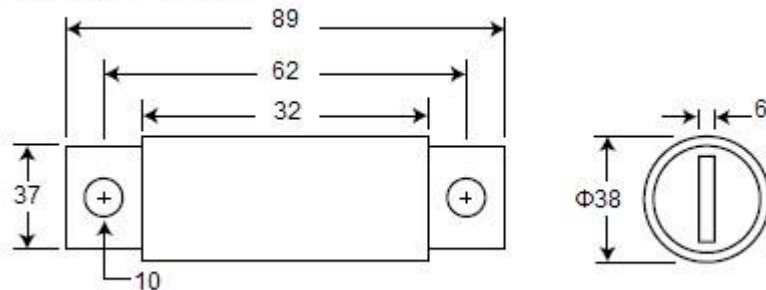

Fig. 2: 500-1000A



电动汽车直流快速熔断器 Protection Electric Cars fuses

North American Power fuses



Class:aR

Time-Current Curve

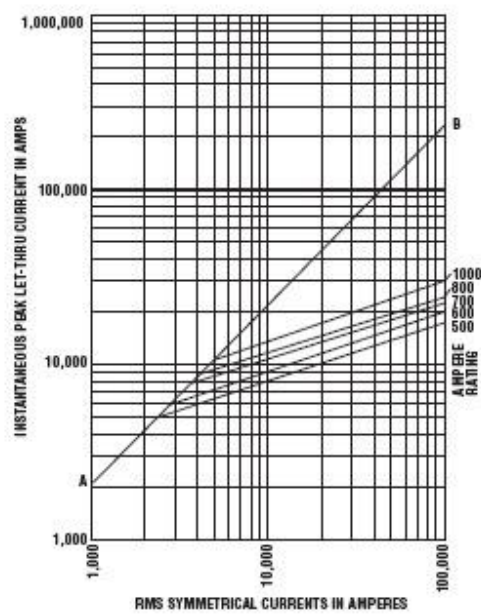
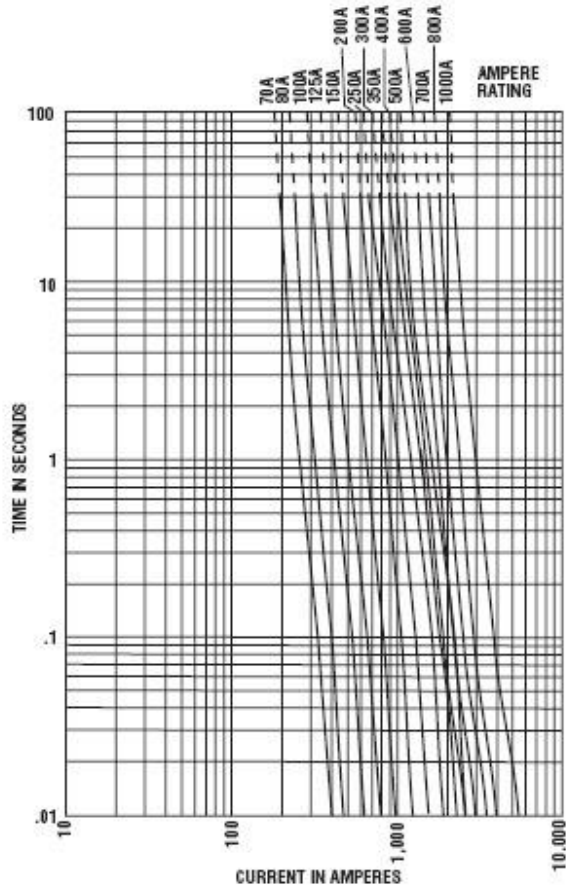

电动汽车直流快速熔断器 Protection Electric Cars fuses

North American Power fuses

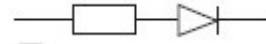

Class:aR

<i>I_e</i> (A)	<i>U_e</i> (V) AC/VDC	KAIERT number	Pre-<i>I</i>²<i>t</i>-value (A²S)	Total <i>I</i>²<i>t</i>-value (A²S)	Power Loss(W)
35	250/250	KRX-35A	50	230	4.2
40		KRX-40A	60	310	5.2
45		KRX-45A	80	390	5.7
50		KRA-50B	100	520	6
60		KRX-60A	140	740	7
70		KRX-70A	330	1400	7.2
80		KRX-80A	430	1850	8.1
90		KRX-90A	570	2450	9
100		KRX-100A	740	3150	10
125		KRX-125A	1130	4850	12.5
150		KRX-150A	1620	6950	15.7
175		KRX-175A	2170	9300	18.5
200		KRX-200A	2790	12000	22
225		KRX-225A	3210	14700	24
250		KRX-250A	3960	18100	27
275		KRX-275A	47200	21600	31
300		KRX-300A	6000	27300	32
350		KRX-350A	10600	48600	39
400		KRX-400A	14500	66100	44
450		KRX-450A	22100	101000	49
500		KRX-500A	28000	128000	54
600		KRX-600A	41100	188000	62
700		KRX-700A	48800	190000	72
800		KRX-800A	59000	230000	84.0

电动汽车直流快速熔断器 Protection Electric Cars fuses

North American Power fuses

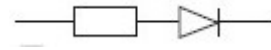

Class:aR

Dimensions (mm)

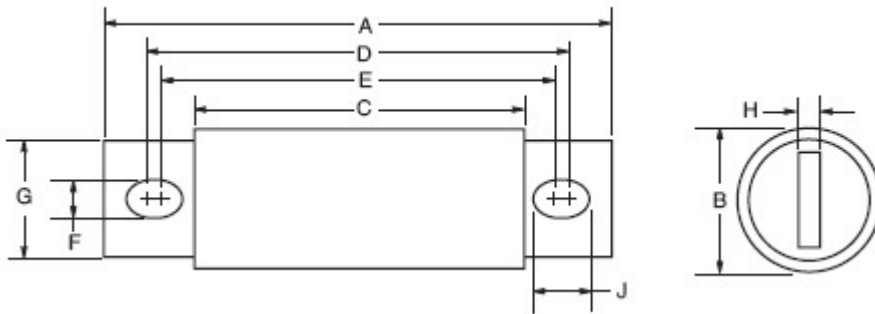

KAIERT number	A	B	C	D	E	F	G	H	J
KRX-35~60	81	21	40	66	57	9	16	3	13
KRX-70~200	80	31	40	62	56	9	25	5	12
KRX-250~600	98	38	40	75	57	11	25	6	19
KRX-700~800	98	51	40	77	58	11	37	6	20



电动汽车直流快速熔断器 Protection Electric Cars fuses

North American Power fuses

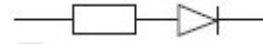

Class:aR

- Time-Current Curve

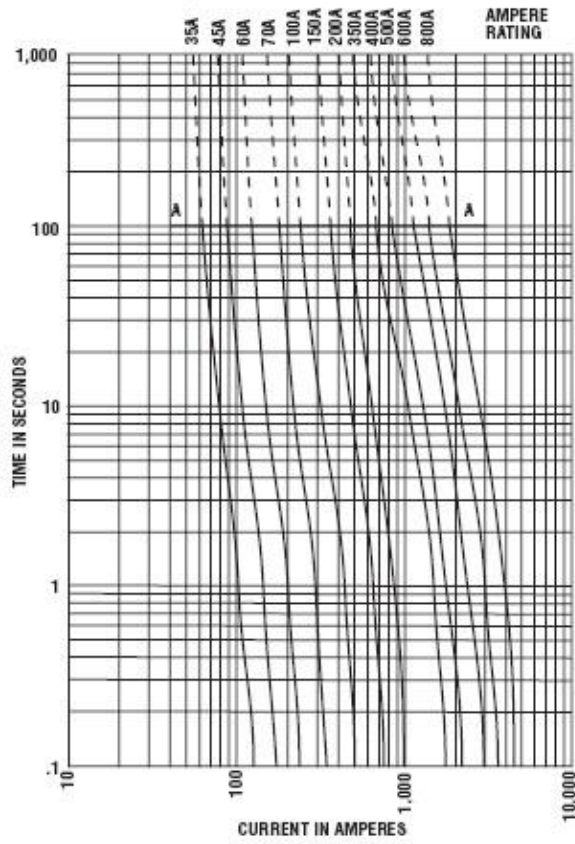

- Cut-Off Characteristics

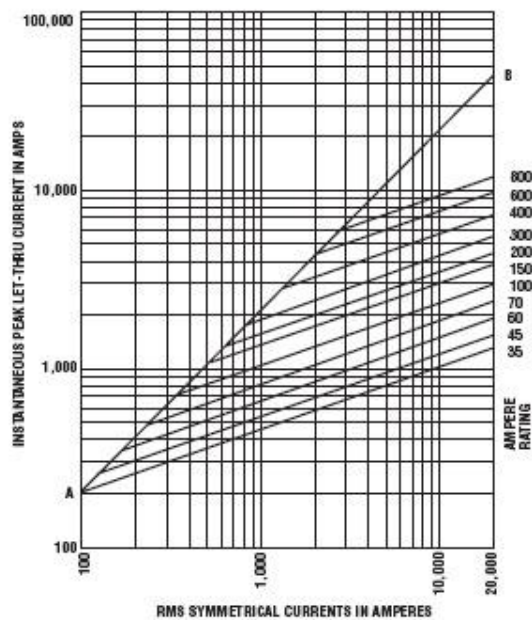

电动汽车直流快速熔断器 Protection Electric Cars fuses

North American Power fuses



Class:aR

<i>I_e</i> (A)	<i>U_e</i> AC/VDC	KAIERT number	Pre-<i>I</i>²<i>t</i>-value (A²S)	Total <i>I</i>²<i>t</i>-value (A²S)	Power Loss(W)
35	500/500	KRH-35B	130	920	5.5
40		KRH-40B	180	1250	6.9
50		KRH-50B	280	1930	8.0
60		KRH-60B	410	2700	9.4
70		KRH-70B	420	2730	12.7
80		KRH-80B	430	2740	13.4
90		KRH-90B	590	3800	15.6
100		KRH-100B	730	4700	16.8
125		KRH-125B	1100	5950	24
150		KRH-150B	2000	10800	26
175		KRH-175B	2800	15300	30
200		KRH-200B	3900	21000	32
225		KRH-225B	4600	23300	39
250		KRH-250B	6300	32200	41
275		KRH-275B	7900	40300	46
300		KRH-300B	9800	49800	51
325		KRH-325B	13700	63800	53
350		KRH-350B	14500	72900	58
400		KRH-400B	19200	96700	65
450		KRH-450B	25700	127000	74
500		KRH-500B	29200	149000	84
600		KRH-600B	41300	206000	108
700		KRH-700B	55000	298000	120
800		KRH-800B	76200	409000	129
1000		KRH-1000B	92000	450000	145
1200		KRH-1200B	122000	600000	180
1400		KRH-1400B	200000	1000000	210
1600		KRH-1600B	290000	1400000	230

电动汽车直流快速熔断器 Protection Electric Cars fuses

North American Power fuses  Class:aR

Dimensions (mm)

KAIERT number	A	B	C	D	E	F	G	H	J
KRH-35~60	81	21	40	66	57	9	16	3	13
KRH-70~100	92	25	53	77	68	9	19	3	13
KRH-125~200	92	31	53	75	68	9	25	5	12
KRH-225~400	110	38	53	88	70	11	25	6	19
KRH-450~600	110	51	53	90	71	11	38	6	20
KRH-700~800	161	64	53	126	88	13.5	51	10	33
KRH-1000~1200	177	76	82	139	114	16	60	11	29
KRH-1400~1600	2 See Drawing for Dimensions								

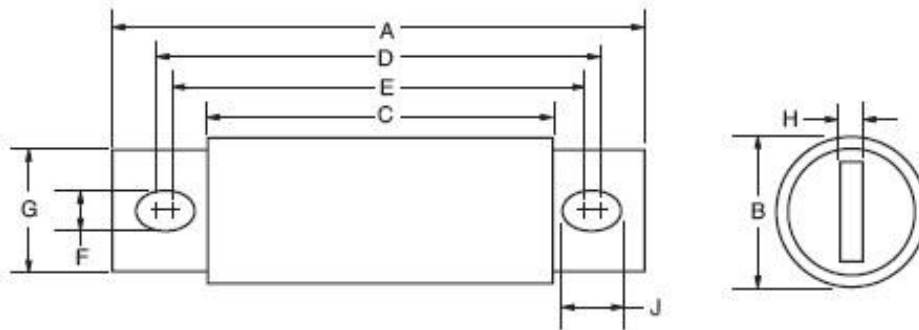

Figure 1: 35 – 1200 Amp Range

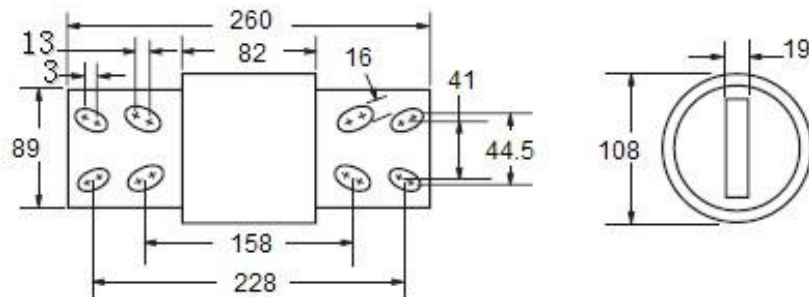
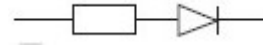

Figure 2: 1400 – 1600 Amp Range

电动汽车直流快速熔断器 Protection Electric Cars fuses

North American Power fuses



Class:aR

- Time-Current Curve

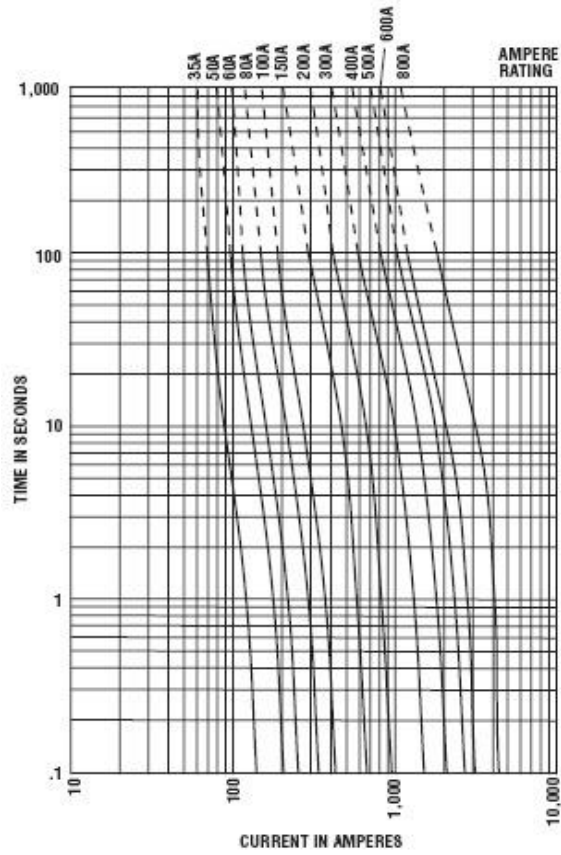

- Cut-Off Characteristics

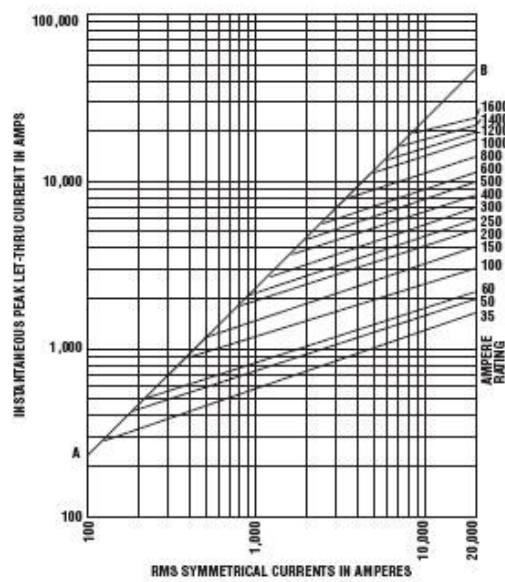

电动汽车直流快速熔断器 Protection Electric Cars fuses

North American Power fuses

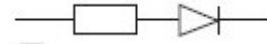

Class:aR

<i>I_e</i> (A)	<i>U_e</i> (V) AC/VDC	KAIERT number	Pre-<i>I</i>²<i>t</i>-value (A²S)	Total <i>I</i>²<i>t</i>-value (A²S)	Power Loss(W)
1	600/600	KRC-1	0.06	0.11	1.3
2		KRC-2	0.22	0.45	2
3		KRC-3	0.5	1	2.3
4		KRC-4	0.9	1.8	2.3
5		KRC-5	1.4	2.8	2.6
6		KRC-6	2.0	4.0	2.8
7		KRC-7	2.7	5.4	3.2
8		KRC-8	3.6	7.1	3.6
10		KRC-10	16	40	3.8
12		KRC-12	22	64	4.2
15		KRC-15	35	100	4.5
17.5		KRC-17.5	45	140	4.5
20		KRC-20	60	170	4.2
25		KRC-25	95	275	7.3
30		KRC-30	140	400	8.7
35		KRC-35	270	1800	5.2
40		KRC-40	350	2400	6.3
45		KRC-45	450	3000	6.7
50		KRC-50	550	3600	7.4
60		KRC-60	800	5400	7.5
70		KRC-70	4000	13000	7.6
80		KRC-80	5300	17000	8.9
90		KRC-90	6700	22000	9.7
100		KRC-100	8300	27000	11
110		KRC-110	9500	31000	11
125		KRC-125	13000	42000	12
150		KRC-150	19000	60000	14
175		KRC-175	25000	80000	16
200		KRC-200	33000	110000	19
225		KRC-225	42000	140000	21
250		KRC-250	52000	170000	26
300		KRC-300	75000	240000	29
350		KRC-350	100000	340000	35
400		KRC-400	130000	490000	37
450		KRC-450	170000	620000	42
500		KRC-500	210000	770000	47

电动汽车直流快速熔断器 Protection Electric Cars fuses

North American Power fuses

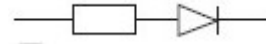

Class:aR

I_e (A)	U_e (V) AC/VDC	KAIERT number	Pre- I^2t -value (A ² S)	Total I^2t -value (A ² S)	Power Loss(W)
600	600/600	KRC-600	300000	1100000	56
700		KRC-700	430000	1700000	57
800		KRC-800	560000	2250000	59
1000		KRC-1000	875000	3500000	72

Dimensions (mm)

Fig. 1: 1-30 & 450-1000A

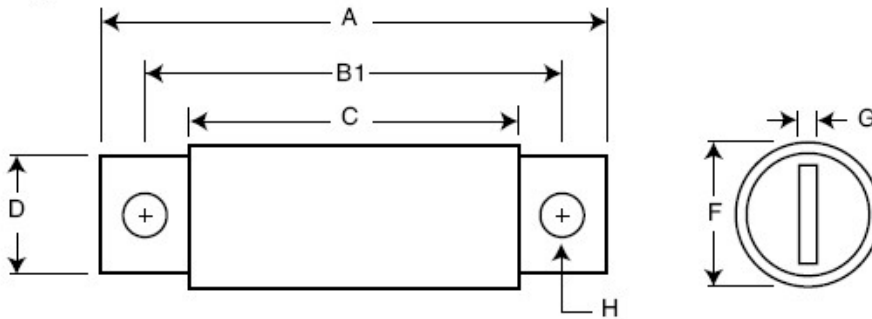
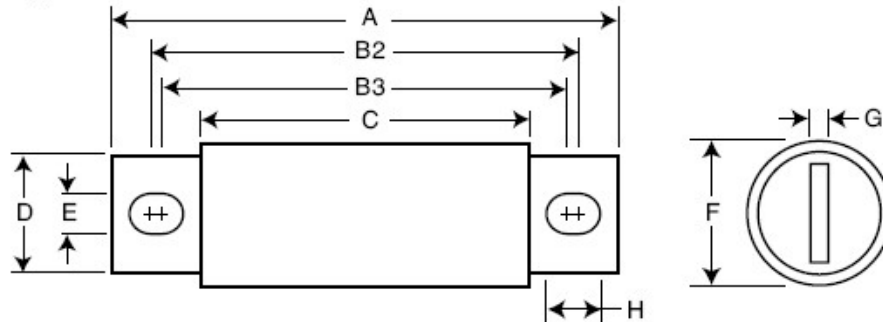

Fig. 2: 35-400A



KAIERT number	Figure	A	B1	B2	B3	C	D	E	F	G	H
KRC-1~30	1	73	64	—	—	48	10	—	14	2	7
KRC-35~60	2	111	—	95	89	70	16	9	21	2.5	12
KRC-70~100	2	127	—	93	93	74	19	10	25	3	16
KRC-110~200	2	140	—	78	78	74	29	10	38	5	20
KRC-225~400	2	157	---	122	116	76	40	14	51	6	14
KRC-450~800	1	159	121	—	—	78	50	—	64	6	14
KRC-1000	1	184	121	—	—	78	70	—	89	10	14

电动汽车直流快速熔断器 Protection Electric Cars fuses

North American Power fuses

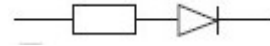

Class:aR

• Time-Current Curve

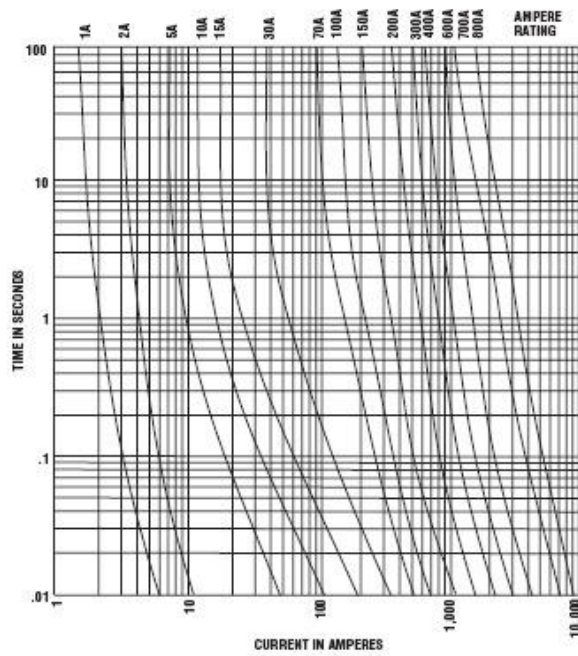
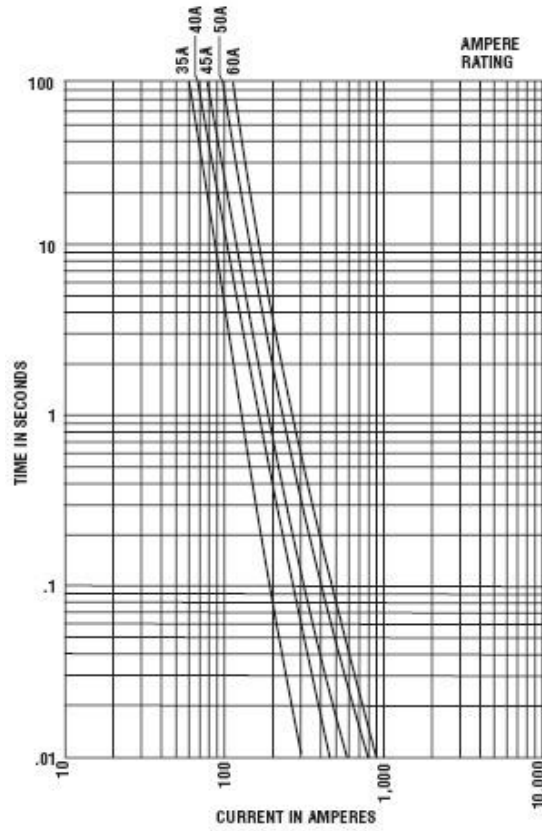

电动汽车直流快速熔断器 Protection Electric Cars fuses

North American Power fuses

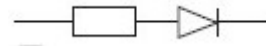

Class:aR

<i>I_e</i> (A)	<i>U_e</i> (V) AC/VDC	KAIERT number	Pre-I²t-value (A²S)	Total I²t-value (A²S)	Power Loss(W)
35	600/600	KRFC-35	270	1800	5.2
40		KRFC-40	350	2400	6.3
45		KRFC-45	450	3000	6.7
50		KRFC-50	550	3600	7.4
60		KRFC-60	800	5400	7.5
70		KRFC-70	4000	13000	7.6
80		KRFC-80	5300	17000	8.9
90		KRFC-90	6700	22000	9.7
100		KRFC-100	8300	27000	11
110		KRFC-110	9500	31000	11
125		KRFC-125	13000	42000	12
150		KRFC-150	19000	60000	14
175		KRFC-175	25000	80000	16
200		KRFC-200	33000	110000	19
225		KRFC-225	42000	140000	21
250		KRFC-250	52000	170000	26
300		KRFC-300	75000	240000	29
350		KRFC-350	100000	340000	35
400		KRFC-400	130000	490000	37
450		KRFC-450	170000	620000	42
500		KRFC-500	210000	770000	47
600		KRFC-600	300000	1100000	56

电动汽车直流快速熔断器 Protection Electric Cars fuses

North American Power fuses  Class:aR

Dimensions (mm)

Fig. 1: 35-60 & 110-600A

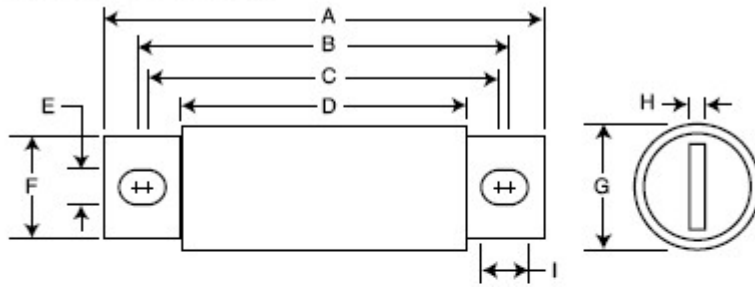
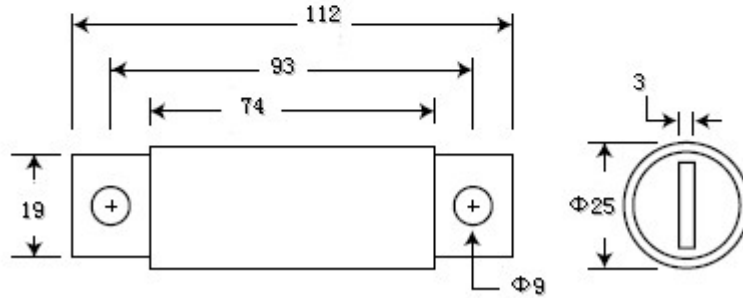

Fig. 2: 70-100A



KAIERT number	Figure	A	B	C	D	E	F	G	H	I
KRFC-35~60	1	111	95	89	70	9	16	21	2.5	12
KRFC-70~100	2	Seeing drawing								
KRFC-110~200	1	112	94	91	74	9	22	31	5	10
KRFC-225~400	1	130	106	91	74	10	25	38	6	18
KRFC-450~600	1	130	111	94	73	10	38	51	6	19

电动汽车直流快速熔断器 Protection Electric Cars fuses

North American Power fuses   Class:aR

• Time-Current Curve

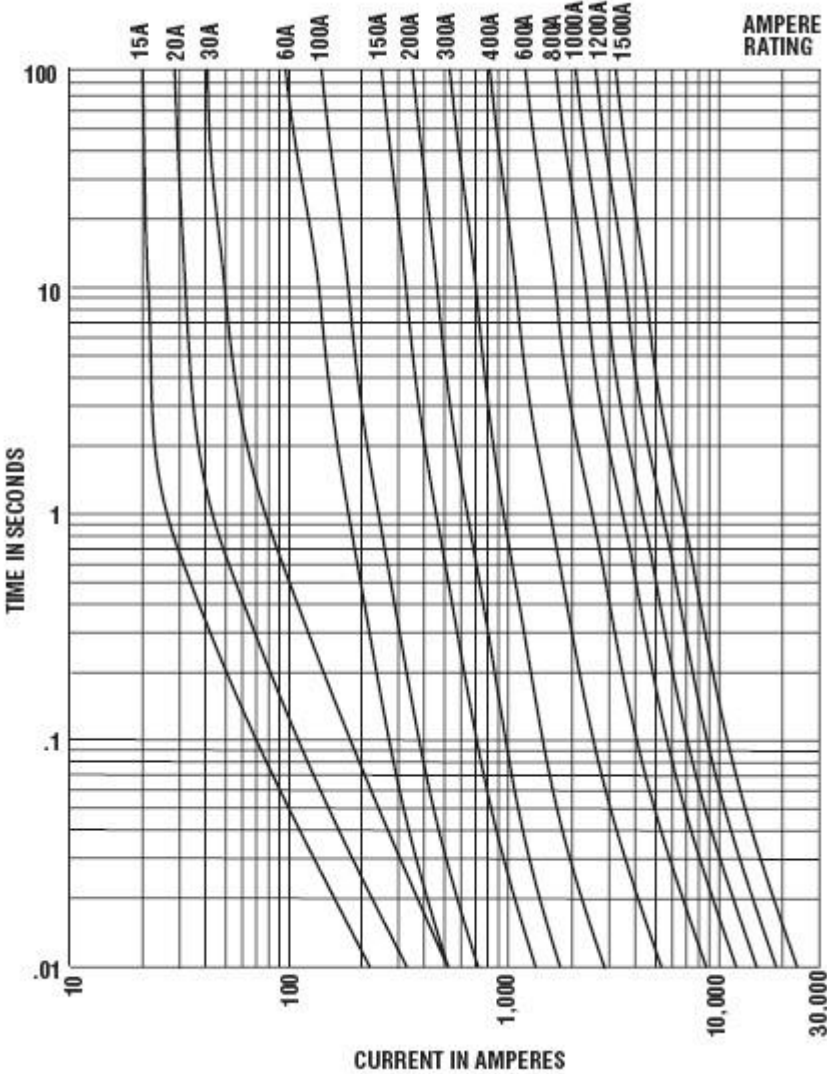

电动汽车直流快速熔断器 Protection Electric Cars fuses

North American Power fuses

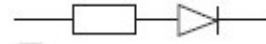

Class:aR

<i>I_e</i> (A)	<i>U_e</i> (V) AC/VDC	KAIERT number	Pre-I²t-value (A²S)	Total I²t-value (A²S)	Power Loss(W)
5	700/700	KRP-5B	1.6	4	1.5
10		KRP-10B	3.6	10	4.0
15		KRP-15B	10	22	5.5
20		KRP-20B	26	60	6.0
25		KRP-25B	44	130	7.0
30		KRP-30B	58	150	9.0
35		KRP-35B	80	370	9.8
40		KRP-40B	100	460	11.5
50		KRP-50B	200	840	13.4
60		KRP-60B	310	1300	15
70		KRP-70B	470	2200	17
80		KRP-80B	620	2900	20
90		KRP-90B	800	3700	23
100		KRP-100B	1030	4800	25
125		KRP-125B	1800	7300	28
150		KRP-150B	2900	11700	32
175		KRP-175B	4200	16700	35
200		KRP-200B	5600	22000	43
225		KRP-225B	7700	31300	45
250		KRP-250B	10500	42500	48
300		KRP-300B	17600	71200	58
350		KRP-350B	23700	95600	65
400		KRP-400B	31000	125000	78
450		KRP-450B	36400	137000	94
500		KRP-500B	45200	170000	107
600		KRP-600B	66700	250000	122
700		KRP-700B	54000	300000	125
800		KRP-800B	78000	450000	140
900		KRP-900B	91500	530000	150
1000		KRP-1000B	120000	600000	170
1200		KRP-1200B	195000	1100000	190

电动汽车直流快速熔断器 Protection Electric Cars fuses

North American Power fuses

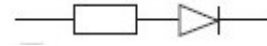

Class:aR

Dimensions (mm)

KAIERT number	Figure	A	B	C	D	E	F	G	H	J
KRP-5~30	1	73	14	48	63	63	6	10	1.5	7
KRP-35~60	1	111	25	72	96	87	9	19	4	13
KRP-70~100	1	111	31	72	94	87	9	25	5	12
KRP-125~200	1	129	38	72	106	89	11	25	6	19
KRP-225~400	1	129	51	72	109	90	11	38	6	20
KRP-450~600	1	180	64	72	145	106	14	51	10	33
KRP-700~800	1	168	51	72	141	129	16	38	6	22
KRP-900~1000	2	See Drawing								
KRP-1200	3	See Drawing								

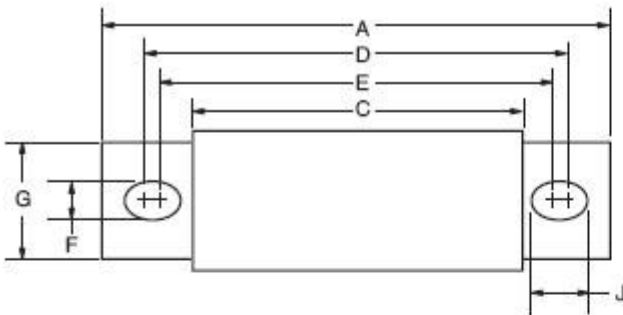

Figure 1: 35 – 100 & 125 – 800 Amp Range

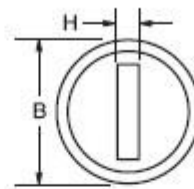

Figure 1A:

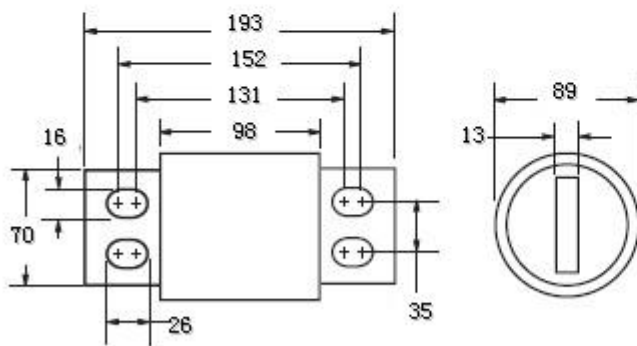

Figure 2: 900 – 1000 Amp Range

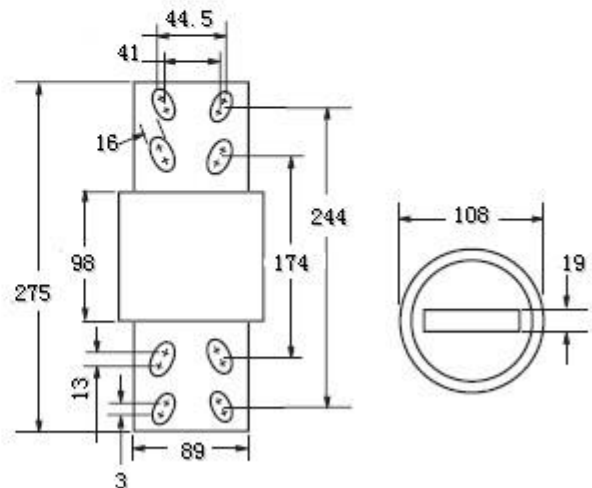
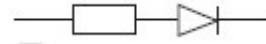

Figure 3: 1200 Amp Range

电动汽车直流快速熔断器 Protection Electric Cars fuses

North American Power fuses



Class:aR

• Time-Current Curve

5 – 30 Amps, 700 Volts

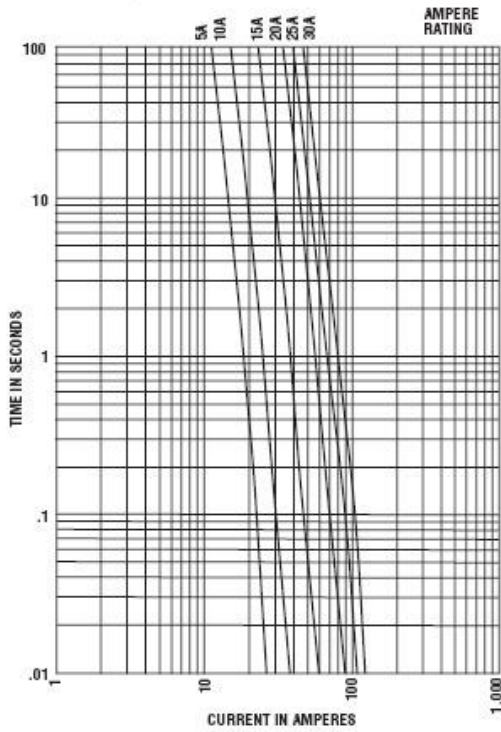

35 – 600 Amps, 700 Volts

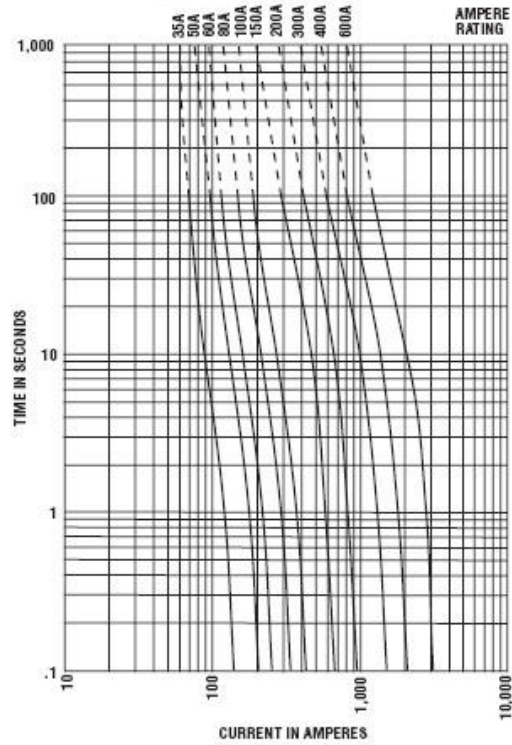

• Cut-Off Characteristics

5 – 30 Amps, 700 Volts

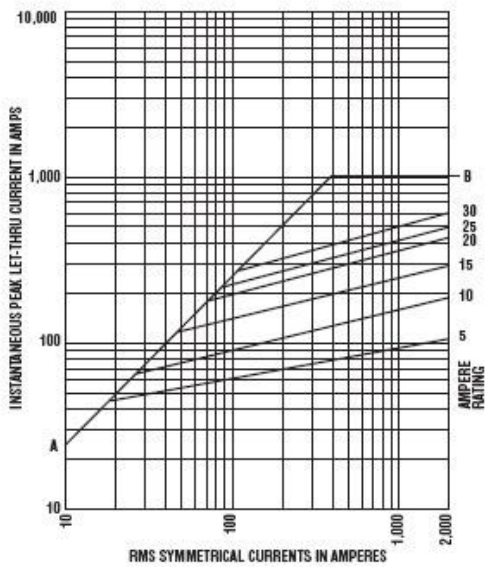

35 – 600 Amps, 700 Volts

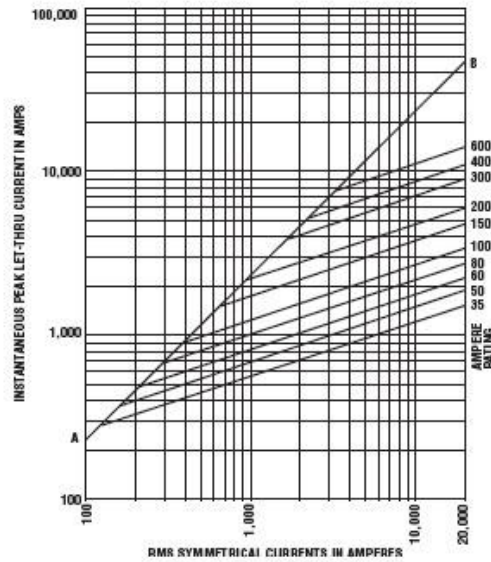

电动汽车直流快速熔断器 Protection Electric Cars fuses

North American Power fuses  Class:aR

• Time-Current Curve and Cut-Off Characteristics

700 – 1200 Amps, 700 Volts

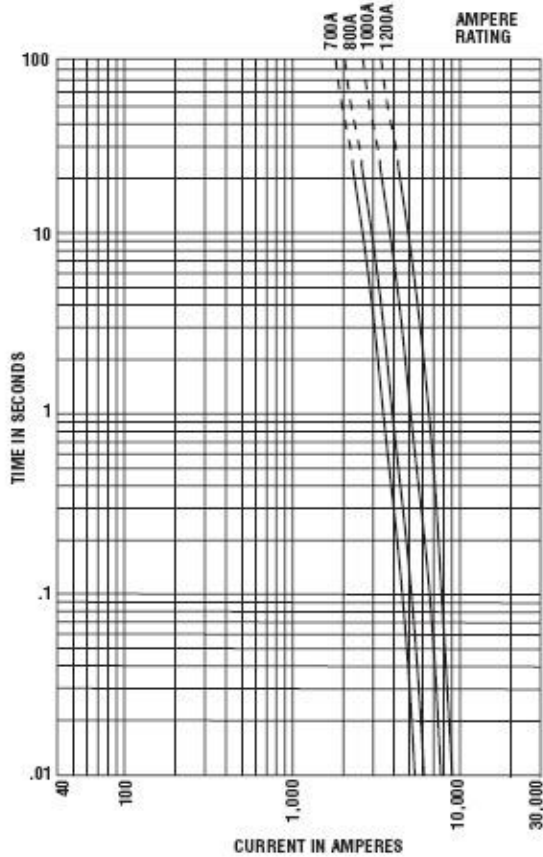

700 – 1200 Amps, 700 Volts

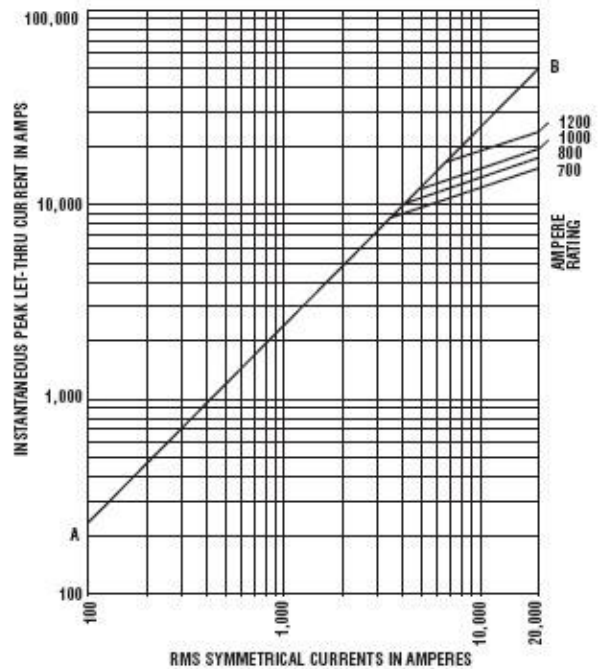

电动汽车直流快速熔断器 Protection Electric Cars fuses

North American Power fuses

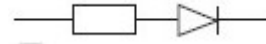

Class:aR

<i>I_e</i> (A)	<i>U_e</i>(V) AC/VDC	KAIERT number	Pre-<i>I</i>²<i>t</i>-value (A²S)	Total <i>I</i>²<i>t</i>-value (A²S)	Power Loss(W)
35	1000/1000	KRJ-35A	210	2000	7
40		KRJ-40A	300	2500	8
50		KRJ-50A	470	3500	10
60		KRJ-60A	670	5000	11
70		KRJ-70A	1100	6900	12
80		KRJ-80A	1550	9700	13
90		KRJ-90A	1900	12000	14
100		KRJ-100A	2800	17500	15
125		KRJ-125A	4800	35000	16
150		KRJ-150A	6300	45000	25
175		KRJ-175A	7500	65000	30
200		KRJ-200A	11700	80000	32
250		KRJ-250A	16000	112000	50
300		KRJ-300A	23500	164000	56
350		KRJ-350A	33000	231000	62
400		KRJ-400A	47000	330000	67
500		KRJ-500A	39500	329000	95
600		KRJ-600A	61000	520000	105
800		KRJ-800A	87000	590000	182
1000		KRJ-1000A	190000	1100000	206
1200		KRJ-1200A	370000	2100000	240
1400		KRJ-1400A	470000	2700000	248
1600		KRJ-1600A	700000	4000000	267
1800		KRJ-1800A	925000	5300000	275
2000		KRJ-2000A	1330000	7600000	284

电动汽车直流快速熔断器 Protection Electric Cars fuses

North American Power fuses  Class:aR

Dimensions (mm)

Fig. 1: 35-2000A

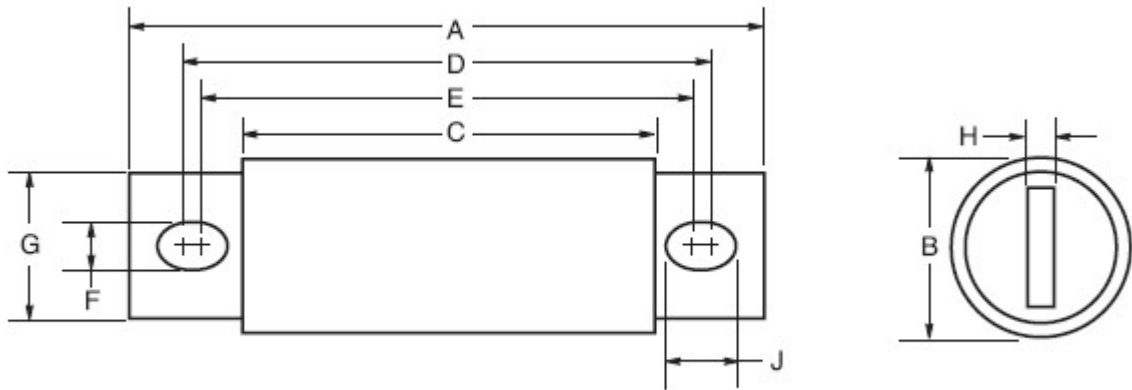

KAIERT number	Figure	A	B	C	D	E	F	G	H	J
KRJ-35~60	1	127	25	79	108	106	9	19	3.5	10
KRJ-70~100	1	125	30	78	108	106	9	25	5	10
KRJ-125~200	1	144	40	83	122	103	11	25	6	21
KRJ-250~400	1	147	51	89	122	105	11	38	6	20
KRJ-500~600	1	183	64	88	152	120	14	51	10	30
KRJ-800~2000	1	173	89	84	139	126	16	70	13	22

电动汽车直流快速熔断器 Protection Electric Cars fuses

North American Power fuses

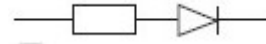

Class:aR

• Time-Current Curve

Time-Current Curve 40A-600A/1000V

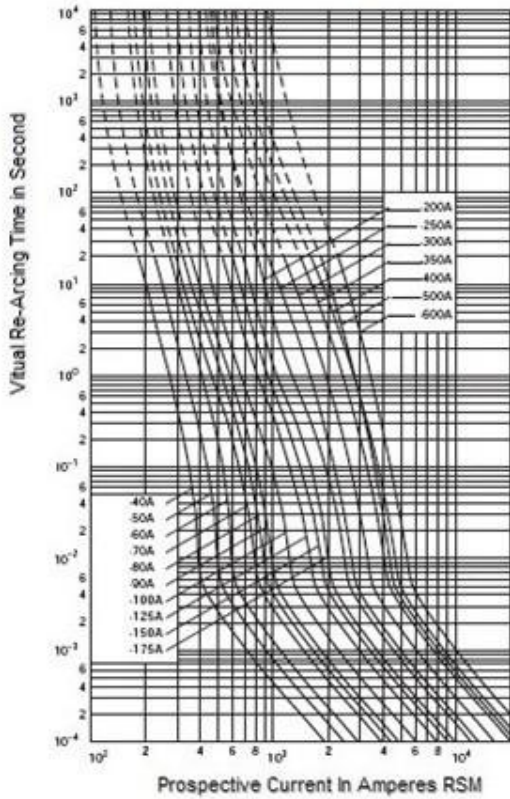

Time-Current Curve 800A-2000A/1000V

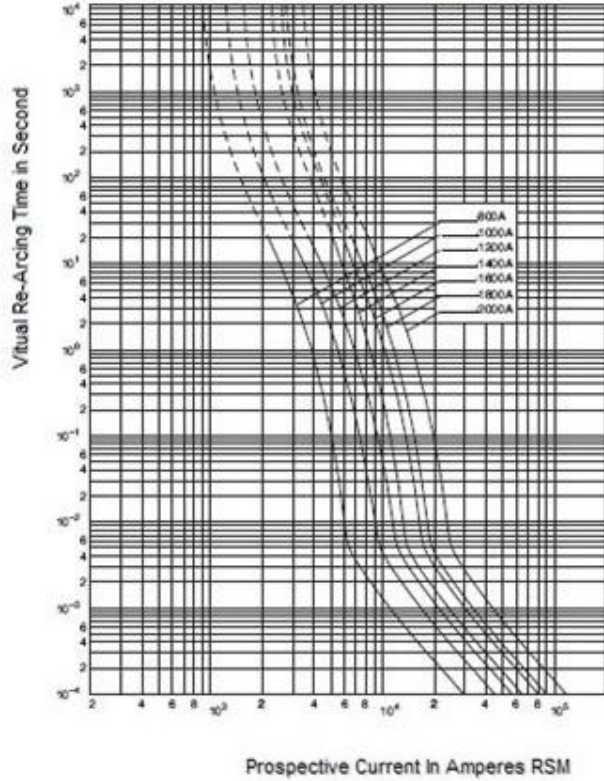

Cut-Off Characteristics

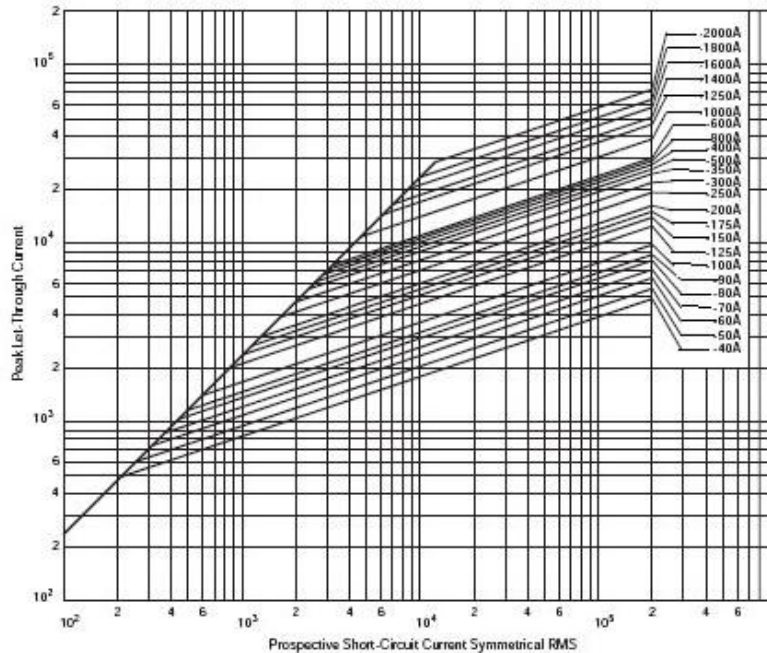

电动汽车直流快速熔断器 Protection Electric Cars fuses

North American Power fuses

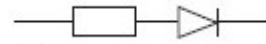

Class:aR

Cross-Reference

Kaiert Number	Bussmann Number	Ferraz Number	
KRA-70B	FWA-70B	A15QS70-4	Z230076J
KRA-80B	FWA-80B	A15QS80-4	C230079J
KRA-100B	FWA-100B	A15QS100-4	J232285J
KRA-125B	FWA-125B	A15QS125-4	M232288J
KRA-150B	FWA-150B	A15QS150-4	T232294J
KRA-200B	FWA-200B	A15QS200-4	Z232299J
KRA-250B	FWA-250B	A15QS250-4	C232302J
KRA-300B	FWA-300B	A15QS300-4	D232303J
KRA-350B	FWA-350B	A15QS350-4	V232317J
KRA-400B	FWA-400B	A15QS400-4	V232318J
KRA-500B	FWA-500B	A15QS500-4	B232324E
KRA-600B	FWA-600B	A15QS600-4	H232330E
KRA-700B	FWA-700B	A15QS700-4	L232333E
KRA-800B	FWA-800B	A15QS800-4	R232338E
KRA-1000B	FWA-1000B	A15QS1000-4	A232346E
KRX-35A	FWX-35A	A30QS35-4	R230015
KRX-40A	FWX-40A	A30QS40-4	S230016
KRX-45A	FWX-45A	A30QS45-4	
KRA-50B	FWA-50B	A30QS50-4	T230017
KRX-60A	FWX-60A	A30QS60-4	V230018
KRX-70A	FWX-70A	A30QS70-4	R226956
KRX-80A	FWX-80A	A30QS80-4	Y226962
KRX-90A	FWX-90A	A30QS90-4	E226968
KRX-100A	FWX-100A	A30QS100-4	D226898
KRX-125A	FWX-125A	A30QS125-4	L226905
KRX-150A	FWX-150A	A30QS150-4	Q226909
KRX-175A	FWX-175A	A30QS175-4	Y226916
KRX-200A	FWX-200A	A30QS200-4	A226918
KRX-225A	FWX-225A	A30QS225-4	F226923
KRX-250A	FWX-250A	A30QS250-4	H226925
KRX-275A	FWX-275A	A30QS275-4	A230276
KRX-300A	FWX-300A	A30QS300-4	W226937
KRX-350A	FWX-350A	A30QS350-4	S226934
KRX-400A	FWX-400A	A30QS400-4	Y226939
KRX-450A	FWX-450A	A30QS450-4	N226953
KRX-500A	FWX-500A	A30QS500-4	H226948

电动汽车直流快速熔断器 Protection Electric Cars fuses

North American Power fuses  Class:aR

Cross-Reference

Kaiert Number	Bussmann Number	Ferraz Number	
KRX-600A	FWX-600A	A30QS600-4	D226944
KRX-700A	FWX-700A	A30QS700-4	V226959
KRX-800A	FWX-800A	A30QS800-4	C226966
KRH-35B	FWH-35B	A50QS35-4	4 Q214834
KRH-40B	FWH-40B	A50QS40-4	4 Y215853
KRH-50B	FWH-50B	A50QS50-4	4 W217392
KRH-60B	FWH-60B	A50QS60-4	4 A218937
KRH-70B	FWH-70B	A50QS70-4	4 B222664
KRH-80B	FWH-80B	A50QS80-4	4 L201513
KRH-90B	FWH-90B	A50QS90-4	4 X211252
KRH-100B	FWH-100B	A50QS100-4	4 A216361
KRH-125B	FWH-125B	A50QS125-4	4 K218417
KRH-150B	FWH-150B	A50QS150-4	4 P219456
KRH-175B	FWH-175B	A50QS175-4	4 A222663
KRH-200B	FWH-200B	A50QS200-4	4 T200968
KRH-225B	FWH-225B	A50QS225-4	4 K201512
KRH-250B	FWH-250B	A50QS250-4	4 W211251
KRH-275B	FWH-275B	A50QS275-4	
KRH-300B	FWH-300B	A50QS300-4	4 D212799
KRH-325B	FWH-325B	A50QS325-4	
KRH-350B	FWH-350B	A50QS350-4	4 T215343
KRH-400B	FWH-400B	A50QS400	4 B216362
KRH-450B	FWH-450B	A50QS450	4 E216871
KRH-500B	FWH-500B	A50QS500	4 L218418
KRH-600B	FWH-600B	A50QS600	4 Q219457
KRH-700B	FWH-700B	A50QS700	4 N223181
KRH-800B	FWH-800B	A50QS800	4 C202287
KRH-1000B	FWH-1000B	A50QS1000	4 V217391
KRH-1200B	FWH-1200B	1200 A50QS1200	4 C217904
KRH-1400B	FWH-1400B		
KRH-1600B	FWH-1600B		
KRC-1	KAC-1		
KRC-2	KAC-2		
KRC-3	KAC-3		
KRC-4	KAC-4		
KRC-5	KAC-5		

电动汽车直流快速熔断器 Protection Electric Cars fuses

North American Power fuses

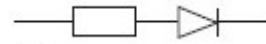

Class:aR

Cross-Reference

Kaiert Number	Bussmann Number	Ferraz Number	
KRC-6	KAC-6	A60X6-4	
KRC-7	KAC-7	A60X7-4	
KRC-8	KAC-8	A60X8-4	
KRC-10	KAC-10	A60X10-4	
KRC-12	KAC-12	A60X12-4	
KRC-15	KAC-15	A60X15-4	
KRC-17.5	KAC-17.5	A60X17.5-4	
KRC-20	KAC-20	A60X20-4	
KRC-25	KAC-25	A60X25-4	
KRC-30	KAC-30	A60X30-4	
KRC-35	KAC-35	A60X35-4	Y214841
KRC-40	KAC-40	A60X40-4	M216878
KRC-45	KAC-45	A60X45-4	D217399
KRC-50	KAC-50	A60X50-4	S218424
KRC-60	KAC-60	A60X60-4	Y219464
KRC-70	KAC-70	A60X70-4	Y214335
KRC-80	KAC-80	A60X80-4	B217397
KRC-90	KAC-90	A60X90-4	Q218422
KRC-100	KAC-100	A60X100-4	Q201517
KRC-110	KAC-110	A60X110-4	
KRC-125	KAC-125	A60X125-4	S214836
KRC-150	KAC-150	A60X150-4	G216873
KRC-175	KAC-175	A60X175-4	Q223183
KRC-200	KAC-200	A60X200-4	H211768
KRC-225	KAC-225	A60X225-4	T214837
KRC-250	KAC-250	A60X250-4	Z217395
KRC-300	KAC-300	A60X300-4	N201515
KRC-350	KAC-350	A60X350-4	X214334
KRC-400	KAC-400	A60X400-4	B215856
KRC-450	KAC-450	A60X450-4	P218421
KRC-500	KAC-500	A60X500-4	E222667
KRC-600	KAC-600	A60X600-4	K211770
KRC-700	KAC-700	A60X700-4	G216367
KRC-800	KAC-800	A60X800-4	T223186
KRC-1000	KAC-1000	A60X1000-4	

电动汽车直流快速熔断器 Protection Electric Cars fuses

North American Power fuses

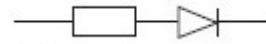

Class:aR

Cross-Reference

Kaiert Number	Bussmann Number	Ferraz Number	
KRFC-35	KBC-35	A60X35-4TA	
KRFC-40	KBC-40	A60X40-4TA	
KRFC-45	KBC-45	A60X45-4TA	
KRFC-50	KBC-50	A60X50-4TA	
KRFC-60	KBC-60	A60X60-4TA	
KRFC-70	KBC-70	A60X70-4TA	
KRFC-80	KBC-80	A60X80-4TA	Q218422
KRFC-90	KBC-90	A60X90-4TA	
KRFC-100	KBC-100	A60X100-4TA	G211767
KRFC-110	KBC-110	A60X110-4TA	
KRFC-125	KBC-125	A60X125-4TA	D216364
KRFC-150	KBC-150	A60X150-4TA	N218420
KRFC-175	KBC-175	A60X175-4TA	
KRFC-200	KBC-200	A60X200-4TA	G212802
KRFC-225	KBC-225	A60X225-4TA	
KRFC-250	KBC-250	A60X250-4TA	D218940
KRFC-300	KBC-300	A60X300-4TA	V212285
KRFC-350	KBC-350	A60X350-4TA	X215346
KRFC-400	KBC-400	A60X400-4TA	A217396
KRFC-450	KBC-450	A60X450-4TA	V219461
KRFC-500	KBC-500	A60X500-4TA	P201516
KRFC-600	KBC-600	A60X600-4TA	J212804
KRP-5B	FWP-5B	A70P5-4	
KRP-10B	FWP-10B	A70P10-4	4 B213326
KRP-15B	FWP-15B	A70P15-4	4 C214845
KRP-20B	FWP-20B	A70P20-4	
KRP-25B	FWP-25B	A70P25-4	4 S216883
KRP-30B	FWP-30B	A70P30-4	4 R217917
KRP-35B	FWP-35B	A70QS35-4	4 D202748
KRP-40B	FWP-40B	A70QS40-4	4 Y213829
KRP-50B	FWP-50B	A70QS50-4	4 T217919
KRP-60B	FWP-60B	A70QS60-4	4 H219473
KRP-70B	FWP-70B	A70QS70-4	4 B201527
KRP-80B	FWP-80B	A70QS80-4	4 X212816
KRP-90B	FWP-90B	A70QS90-4	4 K214346
KRP-100B	FWP-100B	A70QS100-4	4 G214343

电动汽车直流快速熔断器 Protection Electric Cars fuses

North American Power fuses



Class:aR

Cross-Reference

Kaiert Number	Bussmann Number	Ferraz Number	
KRP-125B	FWP-125B	A7OQS125-4	4 L215865
KRP-150B	FWP-150B	A7OQS150-4	4 P218950
KRP-175B	FWP-175B	A7OQS175-4	4 A223192
KRP-200B	FWP-200B	A7OQS200-4	4 V212814
KRP-225B	FWP-225B	A7OQS225-4	
KRP-250B	FWP-250B	A7OQS250-4	4 L217406
KRP-300B	FWP-300B	A7OQS300-4	4 Q218951
KRP-350B	FWP-350B	A7OQS350-4	4 M211266
KRP-400B	FWP-400B	A7OQS400-4	4 J214345
KRP-450B	FWP-450B	A7OQS450-4	4 F214848
KRP-500B	FWP-500B	A7OQS500-4	4 A218431
KRP-600B	FWP-600B	A7OQS600-4	4 Y219993
KRP-700B	FWP-700B	A7OQS700-4	4 E202772
KRP-800B	FWP-800B	A7OQS800-4	4 Z213830
KRP-900B	FWP-900B	A70P900-4	4 D212293
KRP-1000B	FWP-1000B	A70P1000-4	4 D200977
KRP-1200B	FWP-1200B	A70P1200-4	4 F211260
KRJ-35A	FWJ-35A	A100P35-4	4 S223162
KRJ-40A	FWJ-40A	A100P40-4	4 A211232
KRJ-50A	FWJ-50A	A100P50-4	4 Q213799
KRJ-60A	FWJ-60A	A100P60-4	4 G216344
KRJ-70A	FWJ-70A	A100P70-4	
KRJ-80A	FWJ-80A	A100P80-4	4 R201495
KRJ-90A	FWJ-90A	A100P90-4	
KRJ-100A	FWJ-100A	A100P100-4	4 A215832
KRJ-125A	FWJ-125A	A100P125-4	4 D218917
KRJ-150A	FWJ-150A	A100P150-4	4 R223161
KRJ-200A	FWJ-200A	A100P200-4	4 J212781
KRJ-250A	FWJ-250A	A100P250-4	4 Z217372
KRJ-300A	FWJ-300A	A100P300-4	4 T219437
KRJ-350A	FWJ-350A	A100P350-4	4 Q201494
KRJ-400A	FWJ-400A	A100P400-4	4 Z212266
KRJ-500A	FWJ-500A	A100P500-4	4 W214816
KRJ-600A	FWJ-600A	A100P600-4	4 A217373
KRJ-800A	FWJ-800A	A100P800-4	4 B211233
KRJ-1000A	FWJ-1000A	A100P1000-4	4 Y217371



www.Kaiertfuses.com

Name:Xi'an kaiert power electronic manufacturing CO.,LTD
Address: 5th Floor,No.1 Building, No 4955 Shangyuan Road,Caotan Industrial Park,
Xi'an Economic and Technological Development Zone ,Xi'an Chian.

Tel:+86-29-86319515、 +86-29-86214655

Tel:+86-13991253822,13991252383、 13891831927.

Fax:+86-29-86629371